

Reciprocating Compressors Industrial Quality

Air delivery 0.87 to 16.10 m³/min – Pressure 7 to 35 bar



Industrial reciprocating compressors

What do you expect from an industrial quality reciprocating compressor?

As a compressed air user, you expect maximum efficiency and reliability from your air system. Therefore, the most efficient reciprocating compressors are dependable, robust, require little maintenance, have a long service life and provide optimum flexibility. KAESER industrial quality air compressors meet all of these criteria to ensure a compressed air supply of the highest quality.

Advantages of KAESER industrial reciprocating compressors include:

- The knowledge and expertise of nearly 100 years experience in precision engineering and design.
- Made in Germany from the highest quality materials, KAESER's compressor blocks are logically designed and undergo rigorous inspection to guarantee years of reliable service.
- Outstanding performance, dependability, ease of maintenance and long service life.
- Energy-saving drive motors.
- Exceptional versatility to meet the needs of a wide range of compressed air applications.
- Proven oil-lubricated and dry-running compressor technology.

Quality: Made in Germany

Made in Germany: These words represent KAESER's continued commitment to producing specifically tailored compressed air solutions that deliver unrivalled customer satisfaction. Each compressor block is meticulously assembled and tested to the very highest standards at KAESER's reciprocating compressor production centre in Coburg, Germany. Other items such as pressure switches, solenoid valves and air receivers are chosen only from those specialist manufacturers that meet KAESER's uncompromising quality requirements. The logical, modular design of each system provides maximum flexibility, which not only allows system performance to be precisely matched to requirement, but also ensures optimum efficiency.



Made in Germany
KAESER compressor blocks are made from materials of the highest quality. Each component is manufactured, inspected and assembled with care and precision. The result is a highly durable compressor which combines outstanding performance with unrivalled energy efficiency.



High quality cylinder
Our special machining process produces a perfect finish on the inside wall of the cylinder, which makes running-in of the compressor unnecessary as no significant wear takes place after the unit is started for the first time.



Stainless steel valves
The valve reeds in the corrosion resistant stainless steel valves are equipped with lift limiters to ensure air-tight valve closure and to prevent build-up of oil carbon. This achieves exceptional service life and dependability.



Precision machining
Using the most advanced manufacturing processes and with almost 100 years of experience in precision engineering, KAESER's skill and expertise guarantee premium quality products.

Key features:

- Compressor blocks Made in Germany
- Modular design
- Optimum quality assured



QM-system testing

Each compressor system undergoes comprehensive testing before delivery. All components must pass the stringent tests determined by our Quality Management System. All compressors must prove themselves in real-world conditions before we dispatch them to our customers.



Low speed operation ensures maximum reliability and extended service life

Dual systems

- Space-saving design with twin compressor units mounted on a single air receiver
- A reliable source of compressed air at all times, even whilst one unit is being serviced
- Oil-lubricated and dry-running versions
- Ready for immediate use
- Available with sound enclosure (up to KCD 450-100)



Directly coupled unit
coupled to the compressor block. Low speed operation of only 1500 rpm ensures maximum reliability and extended service life.



Dual pressure switches
Dual pressure switches vent the compressors for unloaded starting. The cut-in and cut-out pressures can also be individually set.

Base-mounted systems up to 35 bar

- Ideal for use as an auxiliary compressor with existing air receivers
- Pressure: 35 bar
- Low speed operation (710 – 1160 strokes per min) ensures maximum reliability and extended service life



Highly effective cooling
Aluminium cylinder heads provide exceptional heat dissipation to ensure extended service life.

Integrated compressors

- Dry-running directly coupled systems with 1:1 drive
- Also available as a base-mounted version



KCT 550



Dual cooling
Optimum cooling with double-stream airflow.

Technical Specifications

	10 bar dual systems								7 bar dual systems (dry-running)	
	KCCD 130-100	KCD 350-100	KCD 450-100	KCCD 130-150	KCD 350-350	KCD 450-350	KCD 630-350	KCD 840-350	KCTD 230-100	KCTD 420-100
Displacement l/min	2x 130	2x 350	2x 450	2x 130	2x 350	2x 450	2x 630	2x 840	2x 230	2x 420
Effective air delivery ¹⁾ at 6 bar	2x 80	2x 230	2x 300	2x 80	2x 230	2x 300	2x 440	2x 590	2x 152	2x 252
At 8 bar	2x 73	2x 210	2x 280	2x 73	2x 210	2x 280	2x 410	2x 544	–	–
Motor power ²⁾ kW	2x 0.75	2x 1.7	2x 2.4	2x 0.75	2x 1.7	2x 2.4	2x 3	2x 4	2x 1.5 (2.2) ⁴⁾	2x 2.2
Number of cylinders	2x 1	2x 1	2x 2	2x 1		2x 2		2x 2		
Air receiver volume l	90	90	90	350		350		90		
Sound pressure level ³⁾ dB (A)	70	72	73	70	72	73	79	80	70	71
Width mm	1090		1110	1820				1210		
Depth mm	430	490	500	600		660		570	500	
Height mm	780	830	780	1050	1120	1100	1200	1220	810	780
Weight kg	85	105		115	170	180	230	235	120	165
With sound enclosure										
Sound pressure level ³⁾ dB(A)	60	64	65	-	-	-	-	-	-	-
Start mode	Direct start, unloaded									
Motor protection	Overload protection trip as standard									
Anti-vibration mounts	Standard									

¹⁾ Effective air delivery as per VDMA standard sheet 4362 – ²⁾ Power supply: 400 V, 50 Hz, 3 Ph

³⁾ Sound pressure level as per ISO 2151 and basic norm ISO 9614-2, tolerance: ± 3 dB(A) – ⁴⁾ Actual required power (at maximum motor power)

Technical Specifications

	35 bar, base-mounted								Dry-running, integrated base-mounted compressors									
	K 175-2 -G/H35	K 250-2 -G/H35	K 350-2 -G/H35	K 500-2 -G/H35	K 700-2 -G/H35	K 1000-2 -G/H35	K 1300-2 -G/H35	K 1600-2 -G/H35	KCT 110	KCT 230	KCT 420	KCT 1500	KCT 180	KCT 401	KCT 550	KCT 840	KCT 1000-2	
Displacement l/min	175	250	350	500	700	1000	1300	1600	110	230	420	1500	180	400	550	840	1000	
Effective air delivery ¹⁾ at 6 bar	–								60	152	252	920	110	275	375	575	700	
At 12 bar	136	202	284	407	560	800	1150	1400	–									
Motor power ²⁾ kW	2.2	3	4	5.5	7.5	11	15	18.5	0.75	1.5 (2.2) ⁵⁾	2.2	7.5	1.1	2.4	3	4	7.5	
Max. working pressure bar	35								7				10					
Number of cylinders	2	2	2	2	2	2	3	3	1	2		1		2				
Block speed strokes/min	910	710	760	760	810	1130	960	1160	1500				1500					
Sound pressure level ³⁾ dB (A)	75	72	74	76	80	80	83	83	66	73	75	80	73	75	77	80	80	
Sound power level ⁴⁾ dB(A)	–	–	–	–	–	–	99	99	–	–	–	–	–	–	–	–	–	
Width mm	890	1280	1290	1450	1470	1580	1620		420	500	500	770	510	580	600	640	770	
Depth mm	380	490		590		820	870	830	270	470	560	850	300	475	475	650	620	
Height mm	520	710	690	900		910	950		320	350	360	640	520	400	400	550	660	
Weight kg	60	140	155	220	235	325	315	470	21	38	40	125	30	47	65	70	125	
Auto. star-delta starter	Not necessary			Option	Option	Option	Option	Option	Verify according to installation situation				Verify according to installation situation					
Anti-vibration mounts	Standard								–				–					

¹⁾ Effective air delivery as per VDMA standard sheet 4362 – ²⁾ Power supply: 400 V, 50 Hz, 3 Ph (KCT 110 230V, 1Ph, 50 Hz)

³⁾ Sound pressure level as per ISO 2151 and basic norm ISO 9614-2, tolerance: ± 3 dB(A) – ⁴⁾ Sound power level as per ISO 2151 and basic standard ISO 9614-2, tolerance: ± 3 dB(A)

⁵⁾ Actual required power (at maximum motor power)

Dry-running compressors

Low-maintenance and quiet performance

Directly coupled systems

- Compact design with direct coupling of drive motor and compressor block
- Teflon-coated pistons and low speed operation (1500 strokes per min) ensure exceptional durability
- Internally-coated air receivers



Dual cooling

Highly effective cooling with double-stream airflow. Crank casing internally cooled to enable maximum pressure up to 10 bar (KCT 401 to 840).



Direct drive

Directly coupled units are maintenance-free and eliminate the transmission losses associated with other drive system designs.

Technical Specifications

	7 bar			10 bar, horizontal				10 bar, vertical		
	KCT 110-25	KCT 230-40	KCT 420-100	KCT 401-100	KCT 550-100	KCT 840-100	KCT 840-250	KCT 401-250 St	KCT 550-250 St	KCT 840-250 St
Displacement l/min	110	230	420	400	550	840	840	400	550	840
Effective air delivery ¹⁾ at 6 bar	60	150	252	275	376	575	575	275	376	575
At 8 bar	-	-	-	250	345	525	525	250	345	525
Air receiver volume ²⁾ l	24	40	90	90	90	90	250	250	250	250
Motor power kW	0.75	1.4 (2.2) ³⁾	2.2	2.4	3	4	4	2.4	3	4
Number of cylinders	1	2	2	2	2	2	2	2	2	2
Block speed strokes/min	1500	1500	1500	1500	1500	1500	1500	1500	1500	1500
Sound pressure level ⁴⁾ dB (A)	72	73	75	76	76	78	78	75	76	78
Width mm	640	820	1080	1110	1180	1160	1600	720	720	680
Depth mm	290	475	570	480		670	680	650	640	680
Height mm	680	740	840	910		1010	1160	1770		1920
Weight kg	33	57	76	90	100	110	170	135	145	170
Version with sound enclosure	Enclosure over unit			Enclosure over compressor				Enclosure over compressor		
Sound pressure level ⁴⁾ dB(A)	63	65	65	67	68	68	68	65	68	68

¹⁾ Effective air delivery as per VDMA standard sheet 4362 – ²⁾ Air receiver internally coated – ³⁾ Actual required power (maximum motor power)

⁴⁾ Sound pressure level as per ISO 2151 and basic norm ISO 9614-2, tolerance: ± 3 dB(A)

Tailored solutions

With decades of experience in compressed air system design & planning and satisfied customers in every industrial sector, Kaeser Kompressoren is able to provide the perfect compressed air solution to meet your exact needs.

The modular design concept of our wide range of industrial reciprocating compressors allows us to create ready-to-run compressed air systems to suit any compressed air requirement.

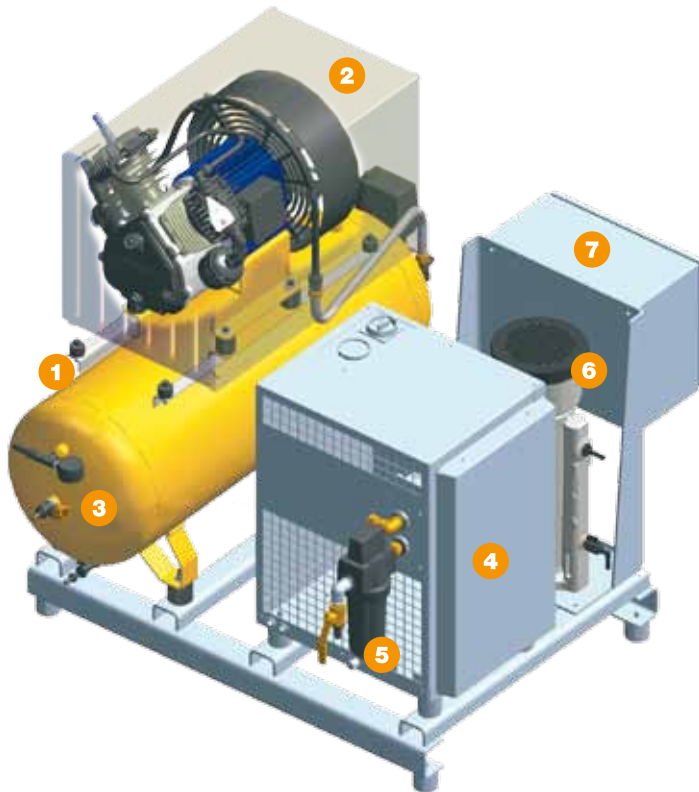

Standard base-frame layout for production of control air for print machinery.

- 1 Reciprocating compressor with direct drive
- 2 Sound enclosure
- 3 Internally-coated air receiver
- 4 Refrigeration dryer
- 5 Microfilter
- 6 Condensate treatment system
- 7 Control unit



Breweries

KAESER industrial reciprocating compressors provide breweries with a dependable supply of clean compressed air e.g. for use in wort aeration.



Research & development

Laboratories require compressed air of the very highest quality, which is never a problem for KAESER compressors.



Winter sports

KAESER compressors ensure ski pistes are evenly covered with snow and help to significantly extend the winter sport season in lower and mid-level resorts.



Fire protection

KAESER compressors provide the reliability that is so essential for fire protection systems.



Viticulture

The annual winter ritual of pruning the grape vines is made simple thanks to reciprocating compressor systems from KAESER.



Printing

Printing works throughout the world rely on the dependability and exceptional performance of KAESER compressor systems to keep production costs to an absolute minimum.

Choose the required grade of treatment according to your field of application:

Air treatment using a refrigeration dryer (pressure dew point +3°C)

Application examples: Selection of treatment classes to ISO 8573-1

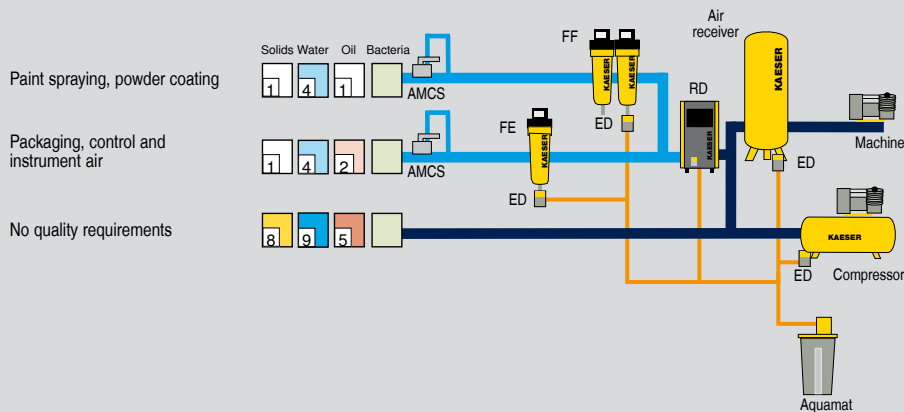

Explanation	
ED	ECO DRAIN
FE / FF	Microfilter
RD	Refrigeration dryer
Aquamat	Aquamat
AMCS	Air-main charging system

Compressed air quality classes to ISO 8573-1(2010):

Solid particles/dust			
Class	max. particle count per m ³ of a particle size with d [µm]*		
	0.1 ≤ d ≤ 0.5	0.5 ≤ d ≤ 1.0	1.0 ≤ d ≤ 5.0
0	e.g. Consult KAESER regarding pure air and cleanroom technology		
1	≤ 20,000	≤ 400	≤ 10
2	≤ 400,000	≤ 6,000	≤ 100
3	Not defined	≤ 90,000	≤ 1,000
4	Not defined	Not defined	≤ 10,000
5	Not defined	Not defined	≤ 100,000
Class	Particle concentration C _p [mg/m ³]*		
6	0 < C _p ≤ 5		
7	5 < C _p ≤ 10		
X	C _p > 10		

Water	
Class	Pressure dew point [°C]
0	e.g. Consult KAESER regarding pure air and cleanroom technology
1	≤ -70 °C
2	≤ -40 °C
3	≤ -20 °C
4	≤ +3 °C
5	≤ +7 °C
6	≤ +10 °C
Class	Concentration of liquid water C _w [mg/m ³]*
7	C _w ≤ 0.5
8	0.5 < C _w ≤ 5
9	5 < C _w ≤ 10
X	C _w ≤ 10

Oil	
Class	Total oil concentration (fluid, aerosol + gaseous) [mg/m ³]*
0	e.g. Consult KAESER regarding pure air and cleanroom technology
1	≤ 0.01
2	≤ 0.1
3	≤ 1.0
4	≤ 5.0
X	> 5.0

*) At reference conditions 20 °C, 1 bar(a), 0% humidity